

Swing Check Valve (W-H44X-16Q)

Application and Features:

Function: Automatically open and close the disc by relying on flow of the medium itself to prevent media backflow;

Applications: Petroleum, refining, water treatment, etc.;

Product Features:

1. Good opening and closing performance under low pressure
2. Low head loss ;
3. Long service life;



Working Principles:

When media flow in specified direction, the disc opens by the action of media; when media backflow, the disc automatically closes fast by the action of flow of the medium itself to prevent media backflow.

Technical Parameters:

Nominal Diameter: DN50~DN600

Nominal Pressure: PN16

Working Temperature: 0~80℃

Working Medium: water

Material:

Part name	Body	Cap	Disc
Material	Ductile Iron	Ductile Iron	EPDM coated Ductile Iron

Installation Dimensions:

Connection Dimension: GB/T 17241.6

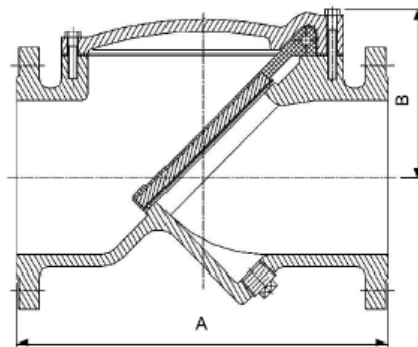

DN	50	65	80	100	125	150	200	250	300	350	400	450	500	600
A	203	216	241	292	330	356	495	622	698	787	914	978	978	1295
B	86	100	110	120	140	150	180	251	310	350	380	400	450	520

Headloss Chart:

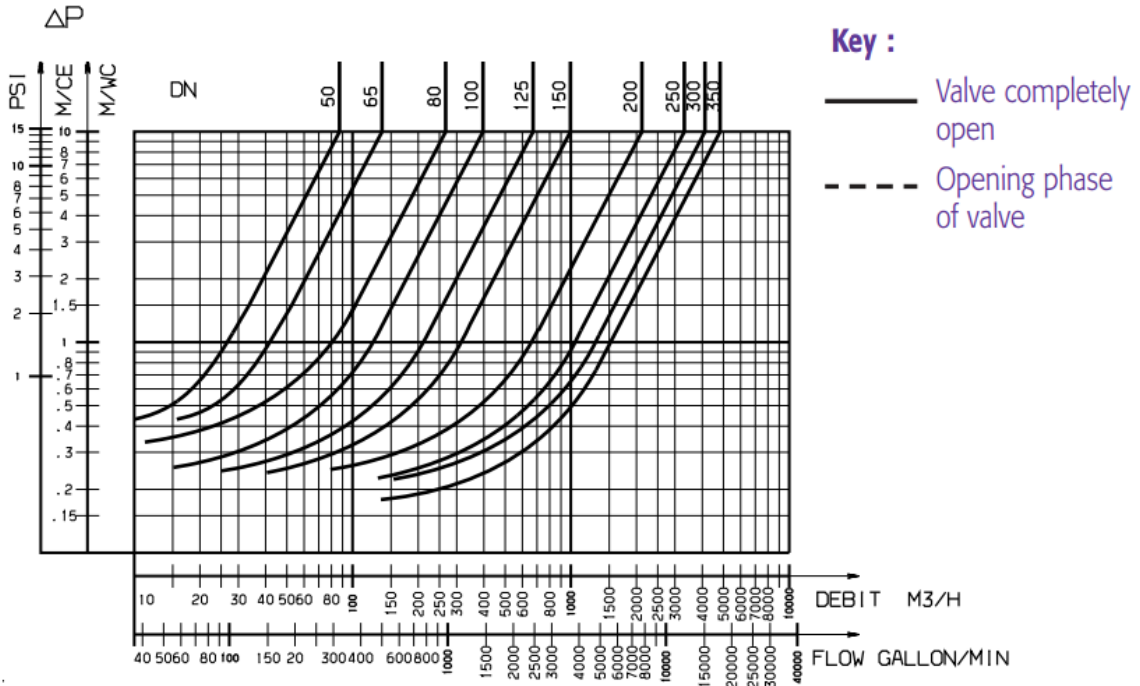

Installation Instructions:

1. Please follow the flow direction on the valve body when installation;
2. This valve can be installed horizontally or vertically, do not allow be installed in the vertical pipe with down flow direction of medium;