

Globe Valve (W-J41H-25C)

◆ Application:

The Watts W-J41H Globe Valve is designed to realize the on-off of pipeline system. It's generally used in petroleum, chemical engineering, metallurgy and water treatment, etc.

◆ Features:

1. Small working stroke, short on-off time;
2. Small volume, simple structure, and convenient manufacture and maintenance;
3. Good sealing performance, small friction between the sealing surfaces, long service life.



◆ Operating Principles:

Driving valve stem rely on the hand wheel to exert pressure downward, the sealing surface of valve disc and seat fit closely, preventing medium flow.

◆ Technical Specification:

Nominal Diameter:	DN50-DN300
Nominal Pressure:	PN25
Working Temperature:	-29℃~425℃
Fluid Medium:	Water, oil and gas
Test Standard:	GB/T 13927-2008

◆ Material:

Part	Body	Bonnet	Stem	Hand Wheel	Filler
Material	Carbon Steel with Spray Paint	Carbon Steel with Spray Paint	Stainless Steel	Cast Iron	Flexible Graphite

◆ Installation Dimensions:

Connection Dimension: GB/T9113;

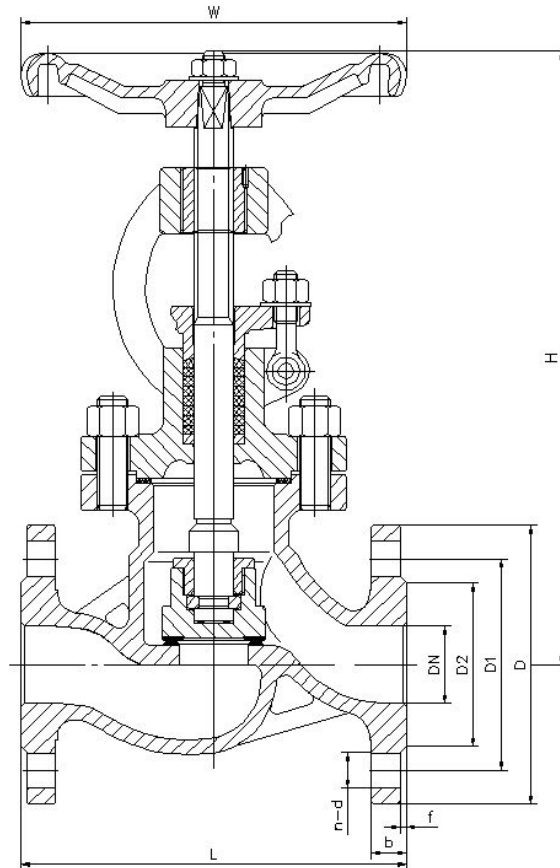

DN	L	D	D1	D2	b	f	n-d	H	W
50	230	165	125	99	20	2	4-18	335	200
65	290	185	145	118	22	2	8-18	375	250
80	310	200	160	132	24	2	8-18	400	280
100	350	235	190	156	24	2	8-22	445	320
125	400	270	220	184	26	2	8-26	500	350
150	480	300	250	211	28	2	8-26	550	400
200	600	360	310	274	30	2	12-26	755	500
250	650	425	370	330	32	2	12-30	905	600
300	750	485	430	389	34	2	16-30	1050	650

◆ Typical Application:

1. Water plant and water source project;
2. Environmental protection;
3. Municipal facilities;
4. Electric power and utilities;
5. Construction industry;
6. Petroleum & Chemical industry;
7. Steel & Metallurgy;
8. Papermaking industry.

◆ Installation Instructions:

- (1) The valve's rated parameters should match the equipment's. Make sure that the valve's rated flow satisfies the actual demand;
- (2) The installer must be trained or experienced so as to operate the installation correctly;
- (3) A thorough check after installation is needed to ensure no errors;
- (4) A thorough cleaning before installation is needed (chemical reagent can be applied if it is necessary) to ensure that there is not any rusting or dirt in the pipe. All the filters must be removed before washing to keep the pipe smoothly open;
- (5) When beginning to wash the system, it is suggested to install the valve on a temporary pipe. After finishing system cleaning, move the valve back and install it on the system's pipe;
- (6) This product should not be used when the fluid medium has high viscosity (contains much grease or mineral oil), or under corrosive circumstances;
- (7) Use flange and the corresponding bolts that meet the standard to connect the valve;
- (8) The direction of flow must accord with the direction of the arrow head on the valve body.